

14 Pin DIP 10 Tap TTL Compatible Active Delay Lines EP83XX & EP83XX-RC

Add "-RC" after part number for RoHS Compliant

PCA Part Number	Tap Delays ($\pm 5\%$ or $\pm 2nS$)	Total Delay ($\pm 5\%$ or $\pm 2nS$)	PCA Part Number	Tap Delays ($\pm 5\%$ or $\pm 2nS$)	Total Delay ($\pm 5\%$ or $\pm 2nS$)
EP8301(-RC)	5	50	EP8322(-RC)	44	440
EP8311(-RC)	6	60	EP8309(-RC)	45	450
EP8317(-RC)	7.5	75	EP8323(-RC)	47	470
EP8302(-RC)	10	100	EP8310(-RC)	50	500
EP8319(-RC)	12.5	125	EP8330(-RC)	55	550
EP8303(-RC)	15	150	EP8324(-RC)	60	600
EP8320(-RC)	17.5	175	EP8331(-RC)	65	650
EP8304(-RC)	20	200	EP8325(-RC)	70	700
EP8321(-RC)	22.5	225	EP8329(-RC)	75	750
EP8305(-RC)	25	250	EP8326(-RC)	80	800
EP8306(-RC)	30	300	EP8332(-RC)	85	850
EP8307(-RC)	35	350	EP8327(-RC)	90	900
EP8308(-RC)	40	400	EP8333(-RC)	95	950
EP8318(-RC)	42	420	EP8328(-RC)	100	1000

†Whichever is greater. Delay times referenced from input to leading edges at 25°C, 5.0V, with no load.

DC Electrical Characteristics					
Parameter	Test Conditions	Min.	Max.	Unit	
V_{OH}	High-Level Output Voltage	$V_{CC} = \min. V_{IL} = \max. I_{OH} = \max$	2.7		V
V_{OL}	Low-Level Output Voltage	$V_{CC} = \min. V_{IH} = \min. I_{OL} = \max$		0.5	V
V_{IK}	Input Clamp Voltage	$V_{CC} = \min. I_I = I_{IK}$		-1.2	V
I_{IH}	High-Level Input Current	$V_{CC} = \max. V_{IN} = 2.7V$		50	μA
		$V_{CC} = \max. V_{IN} = 5.25V$		1.0	mA
I_{IL}	Low-Level Input Current	$V_{CC} = \max. V_{IN} = 0.5V$		-2	mA
I_{OS}	Short Circuit Output Current	$V_{CC} = \max. V_{OUT} = 0.$ (One output at a time)	-40	-100	mA
I_{CCH}	High-Level Supply Current	$V_{CC} = \max. V_{IN} = \text{OPEN}$		150	mA
I_{CCL}	Low-Level Supply Current	$V_{CC} = \max. V_{IN} = 0$		150	mA
T_{RO}	Output Rise Time	$T_d = 500 \text{ nS (0.75 to 2.4 Volts)}$		4	nS
		$T_d > 500 \text{ nS}$		5	nS
N_H	Fanout High-Level Output	$V_{CC} = \max. V_{OH} = 2.7V$		20 TTL Load	
N_L	Fanout Low-Level Output	$V_{CC} = \max. V_{OL} = 0.5V$		10 TTL Load	

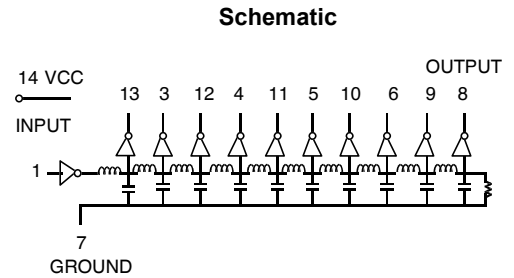

Package

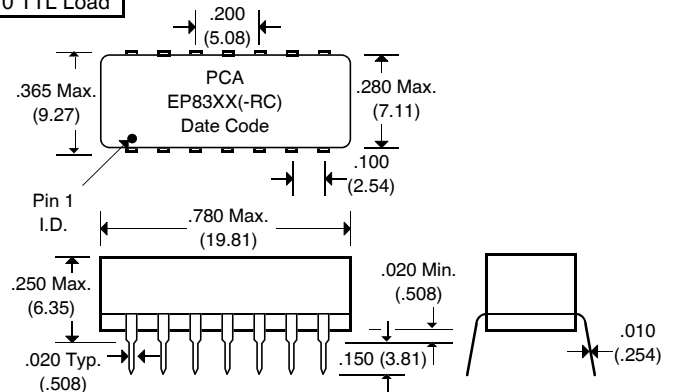

Recommended Operating Conditions				
Parameter	Min.	Max.	Unit	
V_{CC}	4.75	5.25	V	
V_{IH}	2.0		V	
V_{IL}		0.8	V	
I_{IK}		-18	mA	
I_{OH}		-1.0	mA	
I_{OL}		20	mA	
PW^*	40		%	
d^*	40		%	
T_A	0	+70	°C	

*These two values are inter-dependent.

Input Pulse Test Conditions @ 25°C			
Parameter	Unit		
E_{IN}	Pulse Input Voltage	3.2	Volts
PW	Pulse Width % of Total Delay	110	%
T_{RI}	Pulse Rise Time (0.75 - 2.4 Volts)	2.0	nS
P_{RR}	Pulse Repetition Rate @ $T_d = 200 \text{ nS}$	1.0	MHz
	Pulse Repetition Rate @ $T_d > 200 \text{ nS}$	100	KHz
V_{CC}	Supply Voltage	5.0	Volts

Notes :	EP83XX	EP83XX-RC
1. Assembly Process (Leadframe) (Solder Composition) (Assembly Solder)	SnPb	Sn SnPb (RoHS exemption 7a)
2. Peak Solder Rating (per IPC/JESD22-B106-B)	260°C 10 (+2/-0) seconds	260°C 10 (+2/-0) seconds
3. Weight	2.0 grams	2.0 grams
4. Packaging Information (Tube)	24 pieces/tube	24 pieces/tube

Unless Otherwise Specified Dimensions are in Inches /mm $\pm .010 / .25$