

Flyback Power Transformer

EPC3130-X[-S] & EPC3130-X[-S]-LF



- Used in SMPS Flyback Topology
- Designed for use with Power Integration Chip
- Reinforced Insulation (Triple Insulated Wire)
- Add "-LF" after part number for Lead-Free
- UL 94V-0 Recognized Components
- UL 1446 Class F Insulation System
- Very Low Core Loss

Electrical Parameters @ 25° C

PCA Part Number	Chipset	Voltage (Vdc)					Primary OCL (µH ± 10%) @ 10 KHz, 0.1 Vrms	Current (Amp.)			
		V in	V out 1	V out 2	V out 3	V out 4		Sec. 1	Sec. 2	Sec. 3	Sec. 4
EPC3130-1[-S](-LF)	TOP249Y	120-375	19	19	15	N	273	1.8	1.8	.05	N
EPC3130-2[-S](-LF)	TOP234Y	120-375	12	12	15	N	490	1.9	1.9	.05	N
EPC3130-3[-S](-LF)	TOP247Y	120-375	35	35	15	N	342	1.0	1.0	.05	N
EPC3130-4[-S](-LF)	TOP247Y	120-375	24	12	15	24	466	2.0	0.1	.05	.025
EPC3130-5[-S](-LF)	TOP244Y	120-375	24	5	15	N	466	1.0	0.8	.05	N
EPC3130-6[-S](-LF)	Viper 100	120-395	24	24	13	N	256	1.8	1.8	.05	N

• Switching Frequency : 132 KHz • Isolation : 4500 Vrms •

Dielectric Rating (Vrms)		
1 sec. 4500 or 60 sec. 3750	1 sec. 4500 or 60 sec. 3750	1 sec. 1500
Pri. to all Sec. Wdg's & Core	Between Wdg's to Core	Between Pri. Wdg & Bias

• Note : "N" equals Not Required/No Connection •

Schematic

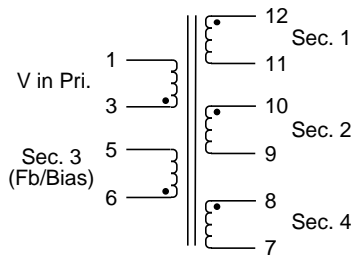

Flux-Band is optional. Add -S to P/N
Example : **EPC3130-2-S-LF**

Notes :	EPC3130-X	EPC3130-X-LF
1. Lead Finish	SnPb	Hot Tin Dip (Sn)
2. Peak Temperature Rating	260°C	260°C
3. Weight	TBD grams	TBD grams
4. Packaging Information (Tray)	TBD pieces/tray	TBD pieces/tray

Package

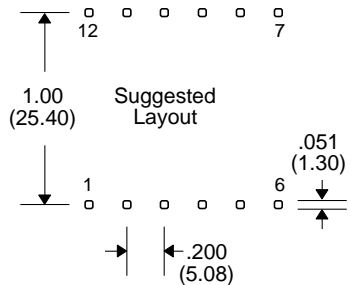
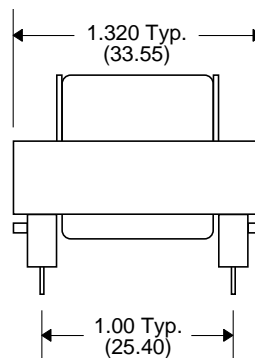
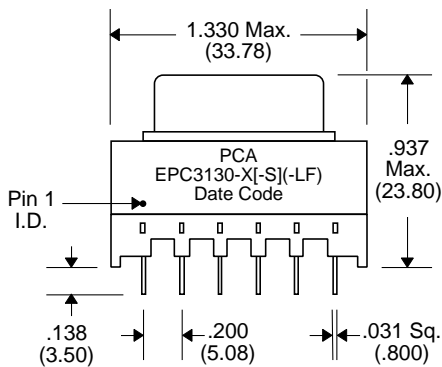

Unless Otherwise Specified Dimensions are in Inches /mm ± .010 / .25